

CRYSTAL UNIT

AEC-Q200

YSX221SC *Small Size*



Applications

Features

- GPS Automotive electronics
- Dimensions: 2.50 x 2.05 x 0.55 mm.
- High precision and high frequency stability.
- Standard Frequency: 12~80MHz
- AEC-Q200 qualified.

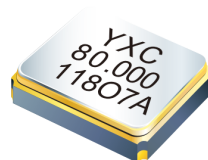

Industrial electronics.

Specifications

Standard Frequency	12~80 MHz
Vibration Mode	AT Fundamental
Load Capacitance	8pF, 10pF, or specify
Frequency Tolerance (at 25 °C)	±10ppm, ±30ppm, or specify
Frequency Versus Temperature Characteristics	±50ppm, or specify
Operating Temperature	-40~+125 °C, or specify
Storage Temperature	-55~+125 °C
Shunt Capacitance	3 pF Max.
Level of Drive	1~200µW Max. (100µW typical)
Aging (at 25 °C)	±2ppm/year Max.

Equivalent Series Resistance(ESR)

Fundamental	
12 ~ 15 MHz	180 Ω Max.
16 ~ 20 MHz	150 Ω Max.
21 ~ 30 MHz	100 Ω Max.
31 ~ 80 MHz	60 Ω Max.

Dimensions and Patterns [unit:mm]

Package Size – Dimensions (Unit: mm)

The technical drawings include:

- Top View:** Shows a square package with dimensions 2.5±0.05 mm by 2.05±0.05 mm. It includes a 'Marking' area and numbered pins 1, 2, 3, and 4.
- Side View:** Shows the package height as 0.55±0.05 mm.
- Bottom View:** Shows the internal layout with dimensions 0.9 mm and 0.7 mm, and numbered pins 1, 2, 3, and 4.
- Top View Crystal Connection:** Shows the electrical connection points for pins 1, 2, 3, and 4, with GND connections.
- Top View Suggested Layout:** Shows the recommended pad dimensions for the crystal connections, with values 1.0, 0.85, 1.0, 0.9, and 0.65 mm.

CRYSTAL UNIT

AEC-Q200

YSX221SC *Small Size*



Reflow Soldering Profile

Pre Heating Temperature

Tp1 ~ Tp2 = + 170 °C

Heating Temperature

TMit = + 220 °C

Peak Temperature

TMax. = + 260 °C

Point of measuring

In case of Solder ability

Terminal.

In case of Resistance to soldering heat

Surface.

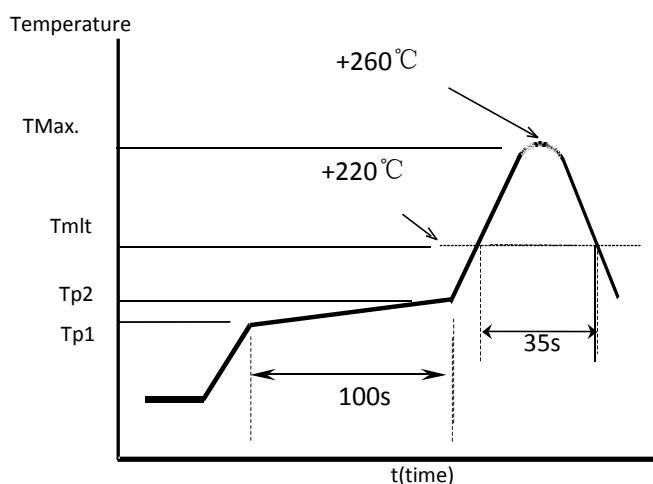

Taping Specification(Unit: mm)

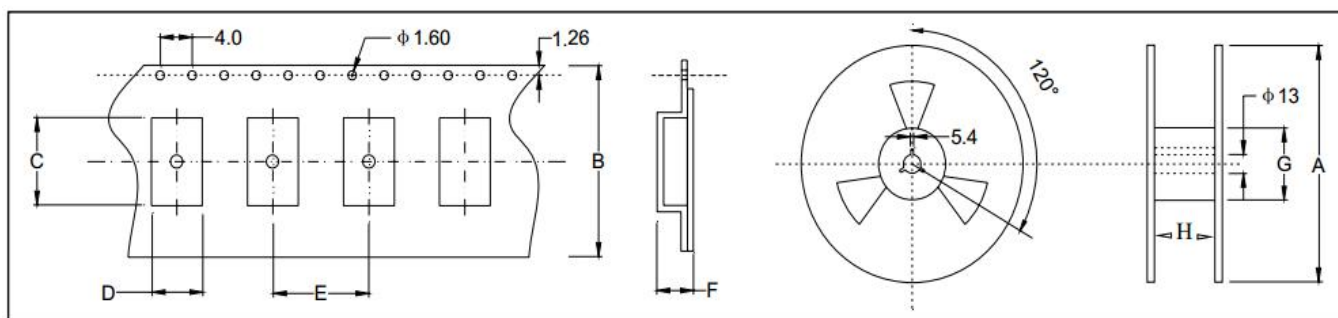

Size	A	B	C	D	E	F	G	H
SMD-2520	180±2.0	8.0±0.3	2.70±0.1	2.25±0.1	4.0±0.1	1.05±0.1	61.0±1.0	8.0±1.0

3000 pcs per reel