



JMP(C.F.H.K.I)5N50A

Description

JMP N-channel MOSFET

Features

- 500V, 5A
- $R_{DS(ON)} = 1.35\Omega$ (Typ.) @ $V_{GS} = 10V, I_D = 2.5A$
- Fast Switching
- 100% Avalanche Tested
- Improved dv/dt Capability

Application

- Switch Mode Power Supply (SMPS)
- Uninterruptible Power Supply (UPS)
- Power Factor Correction (PFC)

Package

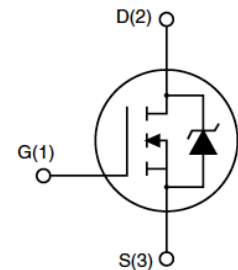
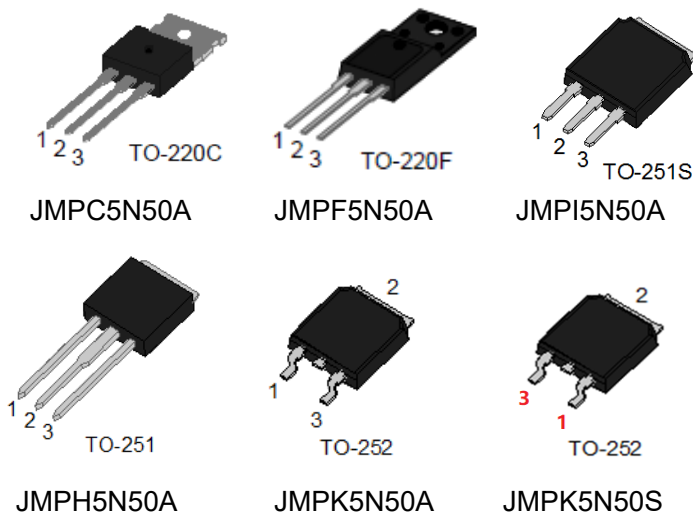

Absolute Maximum Ratings ($T_C = 25^\circ C$ unless otherwise specified)

Symbol	Parameter	Max.			Units
		TO-220F	TO-220C	TO-251/TO-252/ TO-251S	
V_{DSS}	Drain-Source Voltage	500			V
V_{GSS}	Gate-Source Voltage	± 30			V
I_D	Continuous Drain Current	$T_C = 25^\circ C$			A
		$T_C = 100^\circ C$			A
I_{DM}	Pulsed Drain Current ^{note1}	20			A
E_{AS}	Single Pulsed Avalanche Energy ^{note2}	90			mJ
P_D	Power Dissipation	$T_C = 25^\circ C$			W
$R_{\theta JC}$	Thermal Resistance, Junction to Case	30	45		$^\circ C/W$
$R_{\theta JA}$	Thermal Resistance, Junction to Ambient	4.1	2.8		$^\circ C/W$
$R_{\theta JA}$	Thermal Resistance, Junction to Ambient	62.5	60		$^\circ C/W$
T_J, T_{STG}	Operating and Storage Temperature Range	-55 to +150			$^\circ C$



JMP(C.F.H.K.I)5N50A

Electrical Characteristics (T_C=25°C unless otherwise specified)

Symbol	Parameter	Test Condition	Min.	Typ.	Max.	Units
Off Characteristic						
V _{(BR)DSS}	Drain-Source Breakdown Voltage	V _{GS} = 0V, I _D = 250μA	500	-	-	V
I _{DSS}	Zero Gate Voltage Drain Current	V _{DS} = 500V, V _{GS} = 0V, T _J = 25°C	-	-	1	μA
I _{GSS}	Gate to Body Leakage Current	V _{GS} = ±30V	-	-	±100	nA
On Characteristics						
V _{GS(th)}	Gate Threshold Voltage	V _{DS} = V _{GS} , I _D = 250μA	2	3	4	V
R _{DSON}	Static Drain-Source On-Resistance <small>note3</small>	V _{GS} = 10V, I _D = 2.5A	-	1.35	1.6	Ω
Dynamic Characteristics						
C _{iss}	Input Capacitance	V _{DS} = 25V, V _{GS} = 0V, f = 1.0MHz	-	462	-	pF
C _{oss}	Output Capacitance		-	54.2	-	pF
C _{rss}	Reverse Transfer Capacitance		-	8.8	-	pF
Q _g	Total Gate Charge	V _{DD} = 400V, I _D = 5A, V _{GS} = 10V	-	13.5	-	nC
Q _{gs}	Gate-Source Charge		-	2	-	nC
Q _{gd}	Gate-Drain("Miller") Charge		-	6	-	nC
Switching Characteristics						
t _{d(on)}	Turn-On Delay Time	V _{DD} = 250V, I _D = 5A, R _G = 25Ω	-	10	-	ns
t _r	Turn-On Rise Time		-	25	-	ns
t _{d(off)}	Turn-Off Delay Time		-	40	-	ns
t _f	Turn-Off Fall Time		-	52	-	ns
Drain-Source Diode Characteristics and Maximum Ratings						
I _S	Maximum Continuous Drain to Source Diode Forward Current		-	-	5	A
I _{SM}	Maximum Pulsed Drain to Source Diode Forward Current		-	-	20	A
V _{SD}	Drain to Source Diode Forward Voltage	V _{GS} = 0V, I _{SD} = 5A, T _J = 25°C	-	-	1.4	V
t _{rr}	Reverse Recovery Time	V _{GS} = 0V, I _S = 5A, di/dt = 100A/μs	-	220	-	ns
Q _{rr}	Reverse Recovery Charge		-	3	-	μC

Notes: 1. Repetitive Rating: Pulse width limited by maximum junction temperature

2. I_{AS} = 3A, V_{DD} = 50V, R_G = 25Ω, Starting T_J = 25°C

3. Pulse Test: Pulse width ≤ 300μs, Duty Cycle ≤ 1%



Typical Performance Characteristics

Figure 1: Output Characteristics

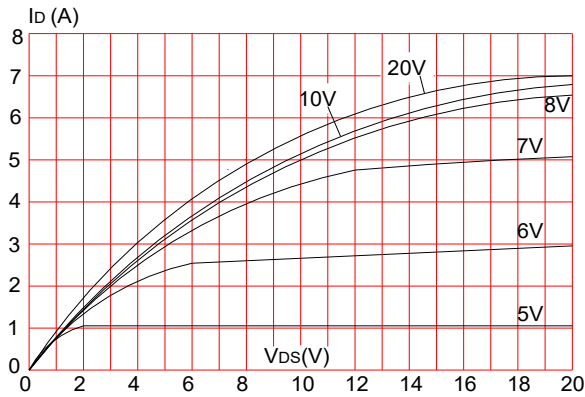

Figure 2: Typical Transfer Characteristics

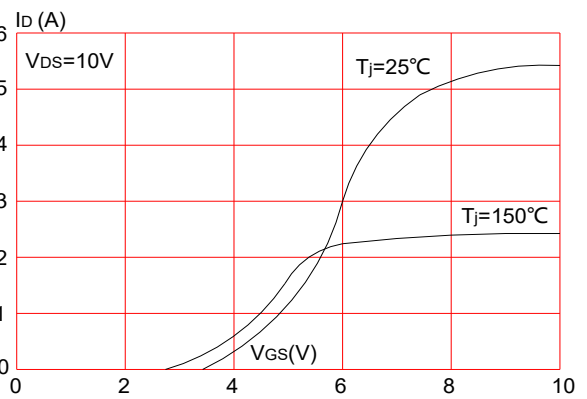

Figure 3: On-resistance vs. Drain Current

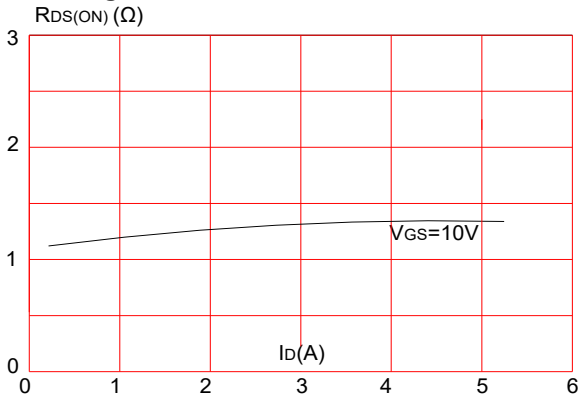

Figure 4: Body Diode Characteristics

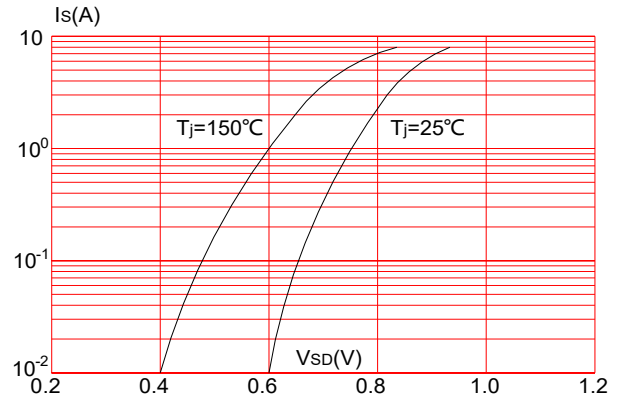

Figure 5: Gate Charge Characteristics

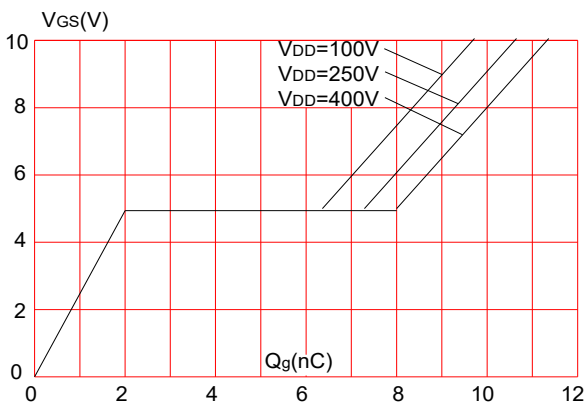
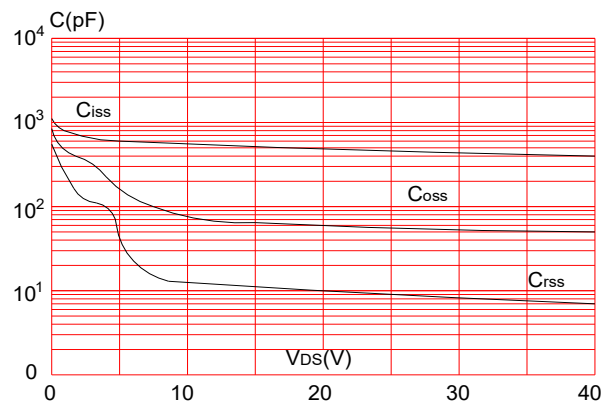

Figure 6: Capacitance Characteristics





JMP(C.F.H.K.I)5N50A

Figure 7: Normalized Breakdown Voltage vs. Junction Temperature

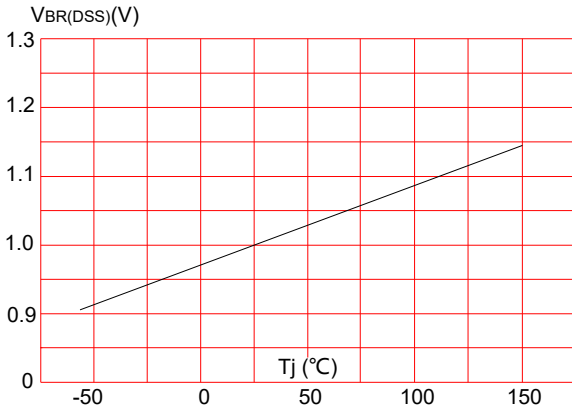

Figure 8: Normalized on Resistance vs. Junction Temperature

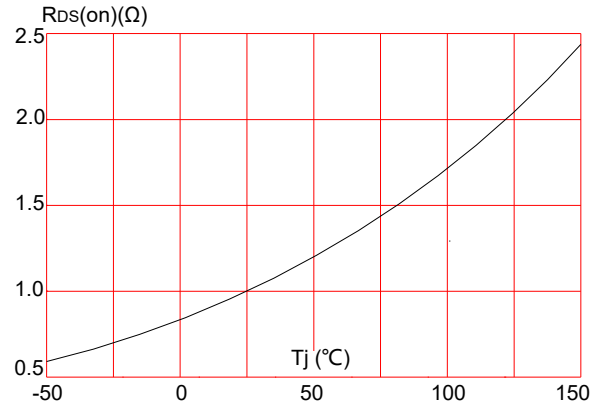

Figure 9: Maximum Safe Operating Area

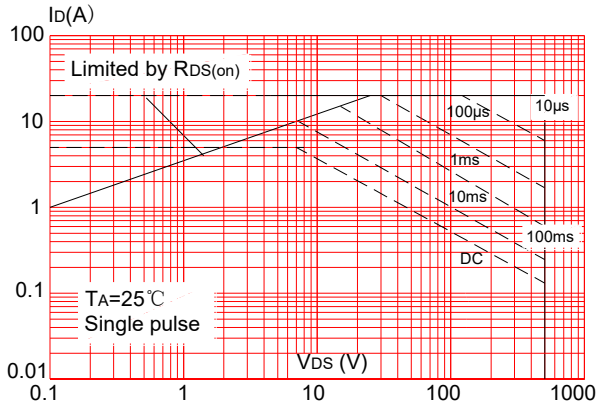

Figure 10: Maximum Continuous Drain Current vs. Case Temperature

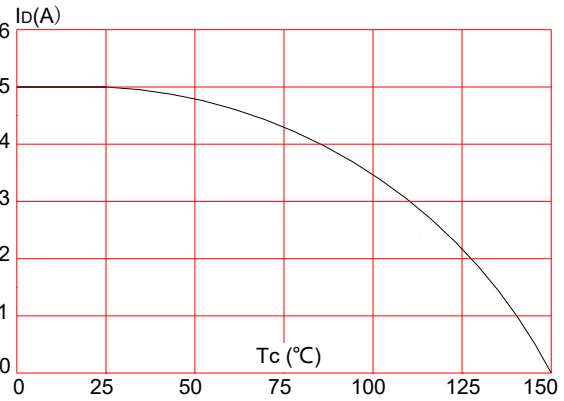

Figure.11: Maximum Effective Transient Thermal Impedance, Junction-to-Case (TO-220C, TO-251, TO-251S, TO-252)

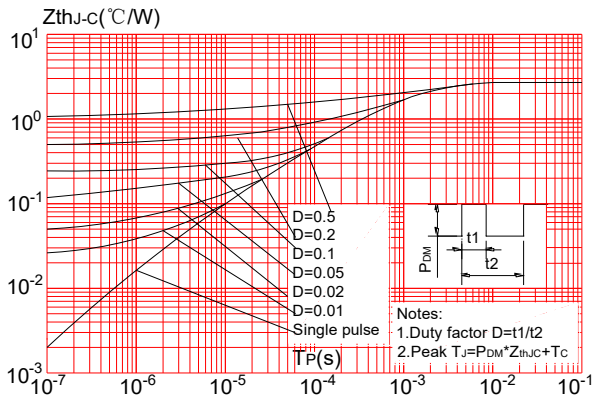
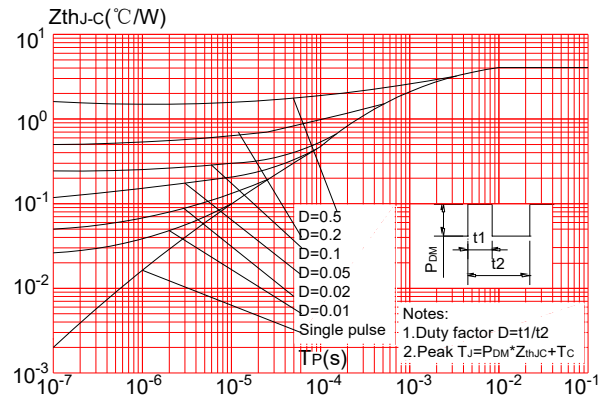

Figure.12: Maximum Effective Transient Thermal Impedance, Junction-to-Case (TO-220F)



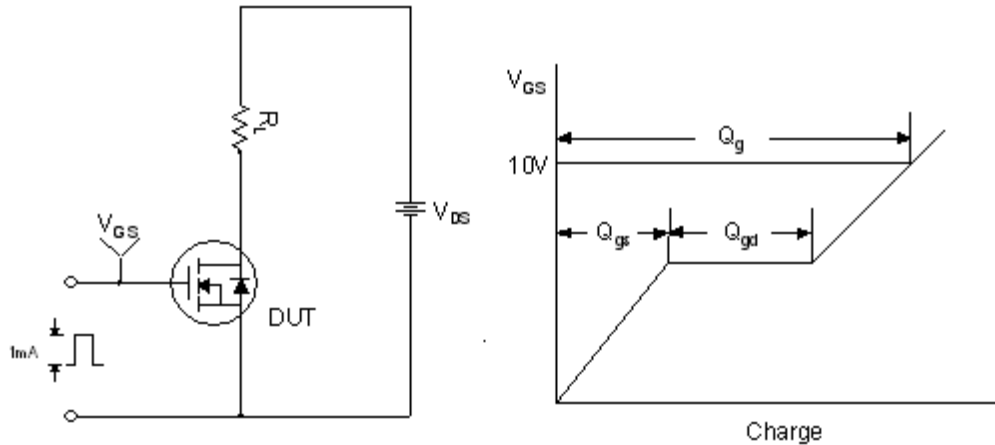

Figure 13. Gate Charge Test Circuit & Waveform

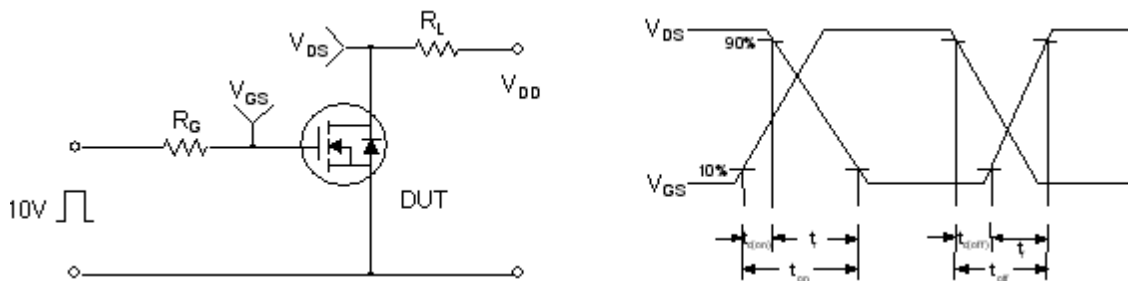

Figure 14. Resistive Switching Test Circuit & Waveforms

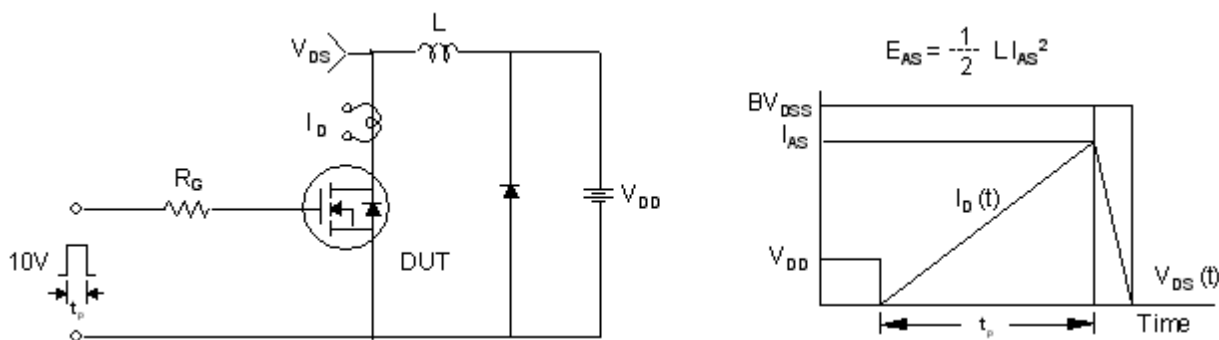

Figure 15. Unclamped Inductive Switching Test Circuit & Waveforms

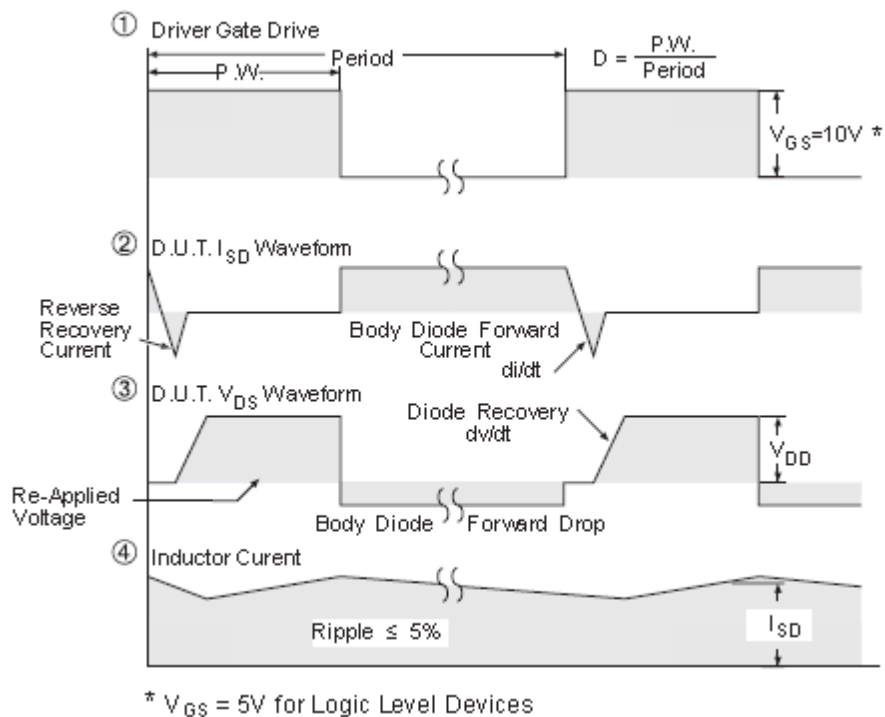
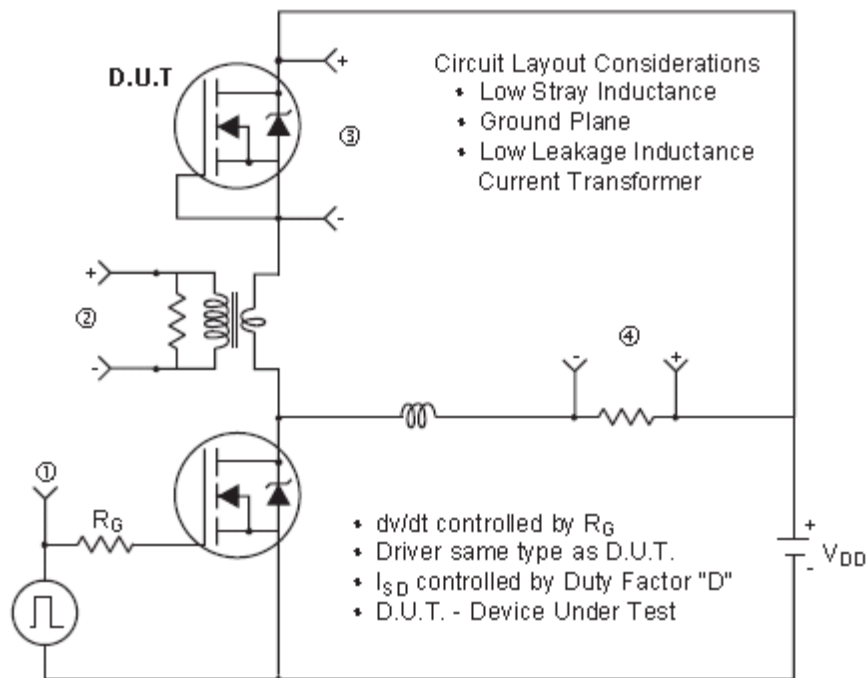
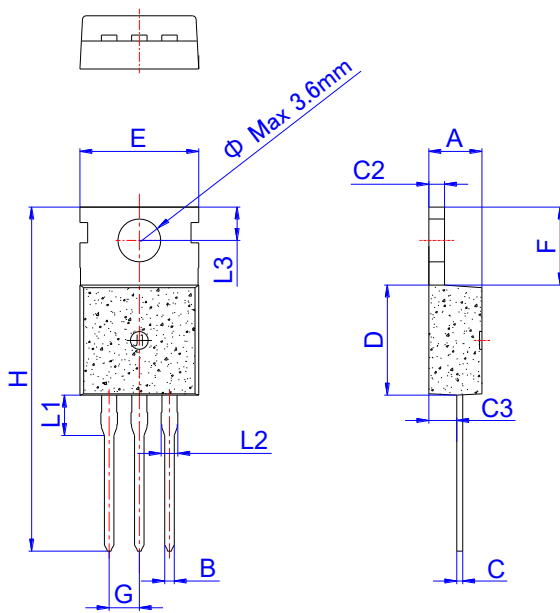

Figure 16. Peak Diode Recovery dv/dt Test Circuit & Waveforms (For N-channel)



JMP(C.F.H.K.I)5N50A

Package Mechanical Data



TO-220C

Ref.	Dimensions					
	Millimeters			Inches		
	Min.	Typ.	Max.	Min.	Typ.	Max.
A	4.40		4.60	0.173		0.181
B	0.70		0.90	0.028		0.035
C	0.45		0.60	0.018		0.024
C2	1.23		1.32	0.048		0.052
C3	2.20		2.60	0.087		0.102
D	8.90		9.90	0.350		0.390
E	9.90		10.3	0.390		0.406
F	6.30		6.90	0.248		0.272
G		2.54			0.1	
H	28.0		29.8	1.102		1.173
L1		3.39			0.133	
L2	1.14		1.70	0.045		0.067
L3	2.65		2.95	0.104		0.116
Φ		3.6			0.142	

Package Information -TO-220C

OUTLINE	TUBE (PCS)	INNER BOX (PCS)	PER CARTON (PCS)
TUBE	50	1,000	8,000



Package Mechanical Data

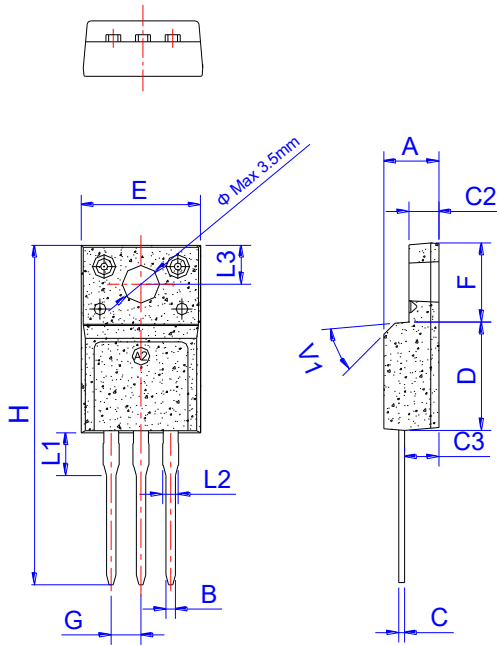

TO-220F

Ref.	Dimensions					
	Millimeters			Inches		
	Min.	Typ.	Max.	Min.	Typ.	Max.
A	4.50		4.90	0.177		0.193
B	0.74	0.80	0.83	0.029	0.031	0.033
C	0.47		0.65	0.019		0.026
C2	2.45		2.75	0.096		0.108
C3	2.60		3.00	0.102		0.118
D	8.80		9.30	0.346		0.366
E	9.80		10.4	0.386		0.410
F	6.40		6.80	0.252		0.268
G		2.54			0.1	
H	28.0		29.8	1.102		1.173
L1		3.63			0.143	
L2	1.14		1.70	0.045		0.067
L3		3.30			0.130	
V1		45°			45°	

Package Information -TO-220F

OUTLINE	TUBE (PCS)	INNER BOX (PCS)	PER CARTON (PCS)
TUBE	50	1,000	8,000



JMP(C.F.H.K.I)5N50A

Package Mechanical Data

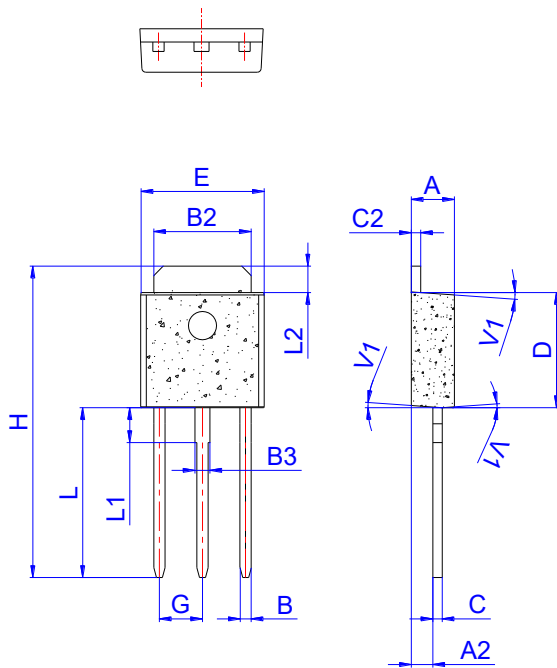

TO-251

Ref.	Dimensions					
	Millimeters			Inches		
	Min.	Typ.	Max.	Min.	Typ.	Max.
A	2.20		2.40	0.086		0.095
A2	0.90		1.20	0.035		0.047
B	0.55		0.65	0.022		0.026
B2	5.10		5.40	0.200		0.213
B3	0.76		0.85	0.030		0.033
C	0.45		0.62	0.018		0.024
C2	0.48		0.62	0.019		0.024
D	6.00		6.20	0.236		0.244
E	6.40		6.70	0.252		0.264
G		2.30			0.091	
H	16.0		17.0	0.630		0.669
L	8.90		9.40	0.350		0.370
L1	1.80		1.90	0.071		0.075
L2	1.37		1.50	0.054		0.059
V1		4°			4°	

Package Information -TO-251

OUTLINE	TUBE (PCS)	INNER BOX (PCS)	PER CARTON (PCS)
TUBE	80	4,000	32,000



JMP(C.F.H.K.I)5N50A

Package Mechanical Data

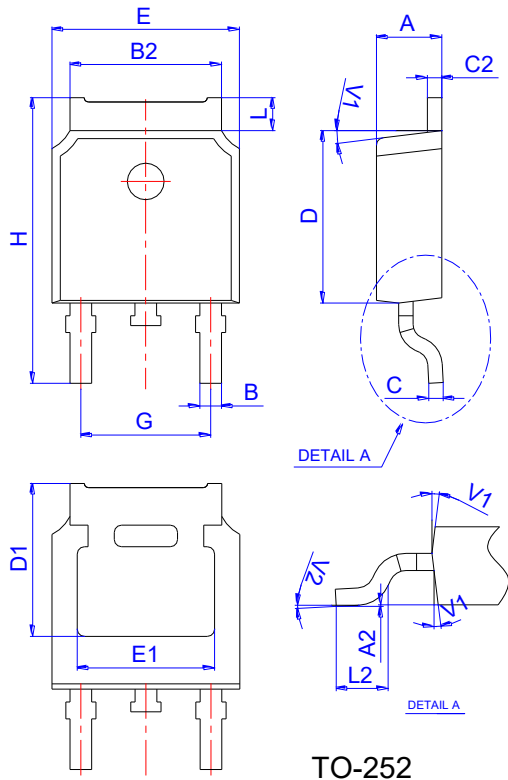

Ref.	Dimensions					
	Millimeters			Inches		
	Min.	Typ.	Max.	Min.	Typ.	Max.
A	2.10		2.50	0.083		0.098
A2	0		0.10	0		0.004
B	0.66		0.86	0.026		0.034
B2	5.18		5.48	0.202		0.216
C	0.40		0.60	0.016		0.024
C2	0.44		0.58	0.017		0.023
D	5.90		6.30	0.232		0.248
D1	5.30REF			0.209REF		
E	6.40		6.80	0.252		0.268
E1	4.63			0.182		
G	4.47		4.67	0.176		0.184
H	9.50		10.70	0.374		0.421
L	1.09		1.21	0.043		0.048
L2	1.35		1.65	0.053		0.065
V1		7°			7°	
V2	0°		6°	0°		6°

Reel Specification-TO-252

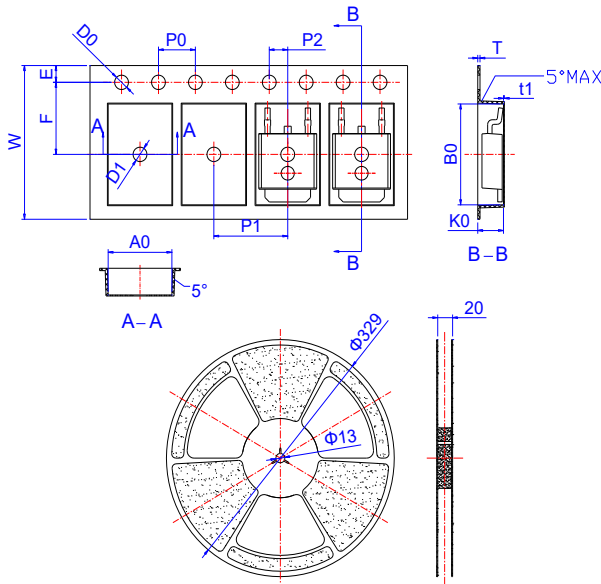

Ref.	Dimensions					
	Millimeters			Inches		
	Min.	Typ.	Max.	Min.	Typ.	Max.
W	15.90	16.00	16.10	0.626	0.630	0.634
E	1.65	1.75	1.85	0.065	0.069	0.073
F	7.40	7.50	7.60	0.291	0.295	0.299
D0	1.40	1.50	1.60	0.055	0.059	0.063
D1	1.40	1.50	1.60	0.055	0.059	0.063
P0	3.90	4.00	4.10	0.154	0.157	0.161
P1	7.90	8.00	8.10	0.311	0.315	0.319
P2	1.90	2.00	2.10	0.075	0.079	0.083
A0	6.85	6.90	7.00	0.270	0.271	0.276
B0	10.45	10.50	10.60	0.411	0.413	0.417
K0	2.68	2.78	2.88	0.105	0.109	0.113
T	0.24		0.27	0.009		0.011
t1	0.10			0.004		
10P0	39.80	40.00	40.20	1.567	1.575	1.583

OUTLINE	REEL (PCS)	PER CARTON (PCS)	TAPE & REEL
TAPING	2,500	25,000	13inch



JMP(C.F.H.K.I)5N50A

Package Mechanical Data

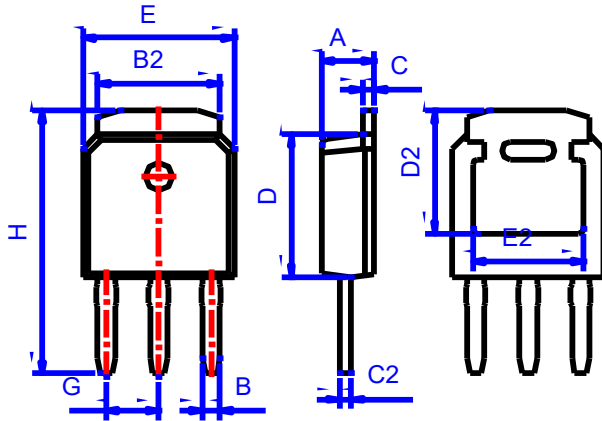

TO-251S

Ref.	Dimensions					
	Millimeters			Inches		
	Min.	Typ.	Max.	Min.	Typ.	Max.
A	2.10	2.30	2.50	0.083	0.091	0.098
B	0.66	0.76	0.86	0.026	0.030	0.034
B2	5.15	5.33	5.48	0.203	0.210	0.216
C	0.44	0.51	0.58	0.017	0.020	0.023
C2	0.44	0.51	0.58	0.017	0.020	0.023
D	5.90	6.10	6.30	0.232	0.240	0.248
D2	5.30 REF			0.209 REF		
E	6.40	6.60	6.80	0.252	0.260	0.268
E2	4.83 REF			0.190 REF		
G	2.19	2.29	2.39	0.086	0.090	0.094
H	10.60	11.20	11.80	0.417	0.441	0.465

Package Information-TO-251S

OUTLINE	TUBE (PCS)	INNER BOX (PCS)	PER CARTON (PCS)
TUBE	80	4,000	32,000

Information furnished in this document is believed to be accurate and reliable. However, Jiangsu JieJie Microelectronics Co.,Ltd assumes no responsibility for the consequences of use without consideration for such information nor use beyond it.

Information mentioned in this document is subject to change without notice, apart from that when an agreement is signed, Jiangsu JieJie complies with the agreement.

Products and information provided in this document have no infringement of patents. Jiangsu JieJie assumes no responsibility for any infringement of other rights of third parties which may result from the use of such products and information.

This document is the fourth version which is made in 2-July-2018. This document supersedes and replaces all information previously supplied.



is a registered trademark of Jiangsu JieJie Microelectronics Co.,Ltd.

Copyright ©2018 Jiangsu JieJie Microelectronics Co.,Ltd. Printed All rights reserved.