

1. Description

KIA6206 series are highly precise, low power consumption, high voltage, positive voltage regulators manufactured using CMOS and laser trimming technologies. The series provides large currents with a significantly small dropout voltage. The series is compatible with low ESR ceramic capacitors. The current limiter's foldback circuit also operates as a short protect for the output current limiter and the output pin.

2. Features

- n Highly Accurate: $\pm 2\%$;
- n Output voltage range: 1.5V~5.0V (selectable in 0.1V steps);
- n Low power consumption: Typ. $= 8.0 \mu A$;
- n Large output current : 300mA;
- n Dropout voltage: 0.2V at 100mA and 0.40V at 200mA;
- n Input Stability
- n Be available to regulator and reference voltage;

3. Applications

- n Battery powered equipment;
- n Communication tools;
- n Mobile phones;
- n Portable games;
- n Portable AV systems;
- n Cameras, Video systems;
- n Reference voltage sources.

4. Pinning configuration

Pin	Description	Simplified outline
1	V_{SS}	 <p>(SOT23 Front View)</p>
2	V_{OUT}	
3	V_{IN}	

5.Package information

3K/Reel 30K/Box 360K/CTN

6.Maximum ratings(Ta=25 °C)

Parameter	Symbol	Rating	Units
Input Voltage	V_{IN}	6.5	V
Output Current	I_{OUT}	500	mA
Output Voltage	V_{OUT}	$V_{SS}-0.3 \sim V_{out}+0.3$	V
Power Dissipation	P_D	300	mW
Operating Ambient Temperature	T_{OPR}	-25~+85	°C
Storage Temperature	T_{STG}	-40~+125	°C
Soldering Temperature And Time	T_{Solder}	260°C, 10s	

Note1: The maximum steady state usable output current is dependent on input voltage, heat sinking, lead length of the package and copper pattern of PCB.

7.Block diagram&Typical application

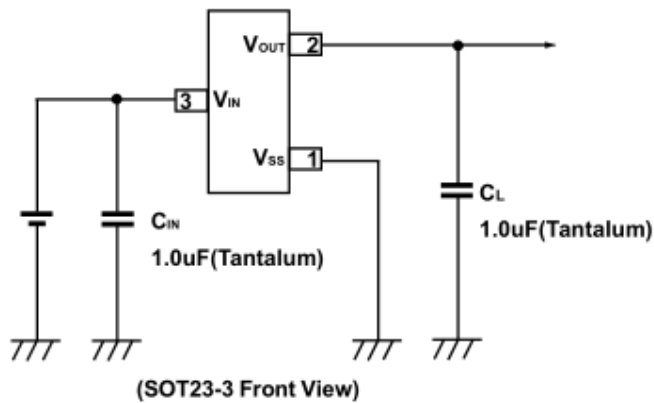

(Typical Application)

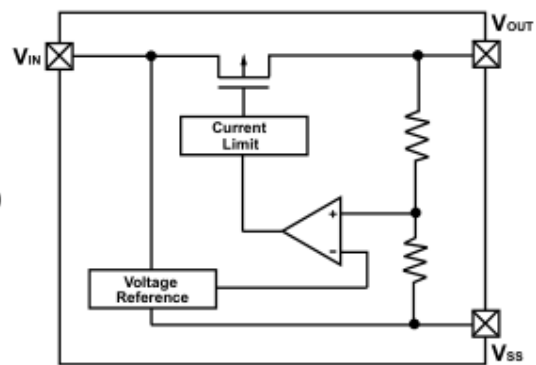

(Block Diagram)

8. Electrical characteristics

KIA6206-1.5V($V_{IN} = V_{OUT} + 1V$, $C_{in} = C_{out} = 1\mu$, $T_A = 25^\circ C$, Unless otherwise Stated)

Parameter	Symbol	Condition	Min	Typ	Max	Unit
Output voltage	$V_{OUT(E)}$ (Note2)	$I_{OUT} = 10mA$, $V_{in} = V_{out} + 1V$	$V_{OUT} * 0.98$	$V_{OUT(T)}$ (Note1)	$V_{OUT} * 1.02$	v
Maximum Output Voltage	$I_{OUT(max)}$	$V_{in} = V_{out} + 1V$	-	100	-	mA
Load Regulation	ΔV_{OUT}	$V_{in} = V_{out} + 1V$, $1mA \leq I_{OUT} \leq 80mA$	-	10	-	mV
Dropout Voltage (Note 3)	V_{dif1}	$I_{OUT} = 20mA$	-	180	-	mV
	V_{dif2}	$I_{OUT} = 50mA$	-	360	-	mV
Supply Current	I_{ss}	$V_{in} = V_{out} + 1V$	-	7	-	μA
Line Regulations	$\frac{\Delta V_{OUT}}{\Delta V_{IN} \cdot V_{OUT}}$	$I_{OUT} = 10mA$ $V_{out} + 1V \leq V_{in} \leq 5V$	-	0.1	-	%/V
Power Supply Ripple Rejection Ratio	PSRR	$V_{in} = [V_{out} + 1]V$ $+1V_p$ -pAC $I_{OUT} = 10mA, f = 1kHz$	-	45	-	dB
Short Circuit Current	I_{short}	$V_{in} = V_{out(T)} + 1.5V$ $V_{out} = V_{ss}$	-	20	-	mA
Over Current Protection	I_{limit}		-	200	-	mA

KIA6206-1.8V($V_{IN} = V_{OUT} + 1V$, $C_{in} = C_{out} = 1\mu$, $T_A = 25^\circ C$, Unless otherwise Stated)

Parameter	Symbol	Condition	Min	Typ	Max	Unit
Output voltage	$V_{OUT(E)}$ (Note2)	$I_{OUT} = 10mA$, $V_{in} = V_{out} + 1V$	$V_{OUT} * 0.98$	$V_{OUT(T)}$ (Note1)	$V_{OUT} * 1.02$	v
Maximum Output Voltage	$I_{OUT(max)}$	$V_{in} = V_{out} + 1V$	-	120	-	mA
Load Regulation	ΔV_{OUT}	$V_{in} = V_{out} + 1V$, $1mA \leq I_{OUT} \leq 80mA$	-	12	-	mV
Dropout Voltage (Note 3)	V_{dif1}	$I_{OUT} = 20mA$	-	180	-	mV
	V_{dif2}	$I_{OUT} = 50mA$	-	360	-	mV
Supply Current	I_{ss}	$V_{in} = V_{out} + 1V$	-	7	-	μA
Line Regulations	$\frac{\Delta V_{OUT}}{\Delta V_{IN} \cdot V_{OUT}}$	$I_{OUT} = 10mA$ $V_{out} + 1V \leq V_{in} \leq 5V$	-	0.1	-	%/V
Power Supply Ripple Rejection Ratio	PSRR	$V_{in} = [V_{out} + 1]V$ $+1V_p$ -pAC $I_{OUT} = 10mA, f = 1kHz$	-	45	-	dB
Short Circuit Current	I_{short}	$V_{in} = V_{out(T)} + 1.5V$ $V_{out} = V_{ss}$	-	25	-	mA
Over Current Protection	I_{limit}		-	200	-	mA

KIA6206-2.8V(VIN =Vout+1V,Cin=Cout=1u,T A =25°C ,Unless otherwise Stated)

Parameter	Symbol	Condition	Min	Typ	Max	Unit
Output voltage	V _{OUT(E)} (Note2)	I _{OUT} =10mA, Vin =Vout+1V	V _{OUT} *0.98	V _{OUT(T)} (Note1)	V _{OUT} *1.02	v
Maximum Output Voltage	I _{OUT(max)}	Vin =Vout+1V	-	300	-	mA
Load Regulation	ΔV _{OUT}	Vin=Vout+1V, 1mA≤I _{OUT} ≤100mA	-	14	-	mV
Dropout Voltage (Note 3)	V _{dif1}	I _{OUT} =80mA	-	180	-	mV
	V _{dif2}	I _{OUT} =200mA	-	380	-	mV
Supply Current	I _{ss}	Vin =Vout+1V	-	8	-	μA
Line Regulations	$\frac{\Delta V_{OUT}}{\Delta V_{IN} \cdot V_{OUT}}$	I _{OUT} =40mA Vout+1V ≤Vin ≤6V	-	0.03	-	%/V
Power Supply Ripple Rejection Ratio	PSRR	Vin= [Vout+1]V +1Vp-pAC I _{OUT} =10mA,f=1kHz	-	50	-	dB
Short Circuit Current	I _{short}	Vin=Vout(T)+1.5V Vout=V _{ss}	-	30	-	mA
Over Current Protection	I _{limit}		-	500	-	mA

KIA6206-3.0V(VIN =Vout+1V,Cin=Cout=1u,T A =25°C ,Unless otherwise Stated)

Parameter	Symbol	Condition	Min	Typ	Max	Unit
Output voltage	V _{OUT(E)} (Note2)	I _{OUT} =10mA, Vin =Vout+1V	V _{OUT} *0.98	V _{OUT(T)} (Note1)	V _{OUT} *1.02	v
Maximum Output Voltage	I _{OUT(max)}	Vin =Vout+1V	-	300	-	mA
Load Regulation	ΔV _{OUT}	Vin=Vout+1V, 1mA≤I _{OUT} ≤100mA	-	14	-	mV
Dropout Voltage (Note 3)	V _{dif1}	I _{OUT} =80mA	-	180	-	mV
	V _{dif2}	I _{OUT} =200mA	-	380	-	mV
Supply Current	I _{ss}	Vin =Vout+1V	-	8	-	μA
Line Regulations	$\frac{\Delta V_{OUT}}{\Delta V_{IN} \cdot V_{OUT}}$	I _{OUT} =40mA Vout+1V ≤Vin ≤6V	-	0.03	-	%/V
Power Supply Ripple Rejection Ratio	PSRR	Vin= [Vout+1]V +1Vp-pAC I _{OUT} =10mA,f=1kHz	-	50	-	dB
Short Circuit Current	I _{short}	Vin=Vout(T)+1.5V Vout=V _{ss}	-	30	-	mA
Over Current Protection	I _{limit}		-	500	-	mA

KIA6206-3.3V(VIN =Vout+1V,Cin=Cout=1u,T A =25°C ,Unless otherwise Stated)

Parameter	Symbol	Condition	Min	Typ	Max	Unit
Output voltage	V _{OUT(E)} (Note2)	I _{OUT} =10mA, Vin =Vout+1V	V _{OUT} *0.98	V _{OUT(T)} (Note1)	V _{OUT} *1.02	v
Maximum Output Voltage	I _{OUT(max)}	Vin =Vout+1V	-	300	-	mA
Load Regulation	ΔV _{OUT}	Vin=Vout+1V, 1mA≤I _{OUT} ≤100mA	-	14	-	mV
Dropout Voltage (Note 3)	V _{dif1}	I _{OUT} =80mA	-	180	-	mV
	V _{dif2}	I _{OUT} =200mA	-	380	-	mV
Supply Current	I _{ss}	Vin =Vout+1V	-	9	-	μA
Line Regulations	$\frac{\Delta V_{OUT}}{\Delta V_{IN} \cdot V_{OUT}}$	I _{OUT} =40mA Vout+1V ≤Vin ≤6V	-	0.03	-	%/V
Power Supply Ripple Rejection Ratio	PSRR	Vin= [Vout+1]V +1Vp-pAC I _{OUT} =10mA,f=1kHz	-	50	-	dB
Short Circuit Current	I _{short}	Vin=Vout(T)+1.5V Vout=V _{ss}	-	30	-	mA
Over Current Protection	I _{limit}		-	500	-	mA

Note :

1. V_{OUT (T)} : Specified Output Voltage
- 2.V_{OUT (E)} : Effective Output Voltage (Ie. The output voltage when “V_{OUT (T)}+1.0V”is provided at the Vin pin while maintaining a certain I_{out} value.)
- 3.V_{dif} : V_{IN1} - V_{OUT (E)}
 - V_{IN1} : The input voltage when V_{OUT (E)}’ appears as input voltage is gradually decreased.
 - V_{OUT (E)}’ =A voltage equal to 98% of the output voltage whenever an amply stabilized I_{out} {V_{OUT (T)}+1.0V} is input.

9. Typical performance characteristics

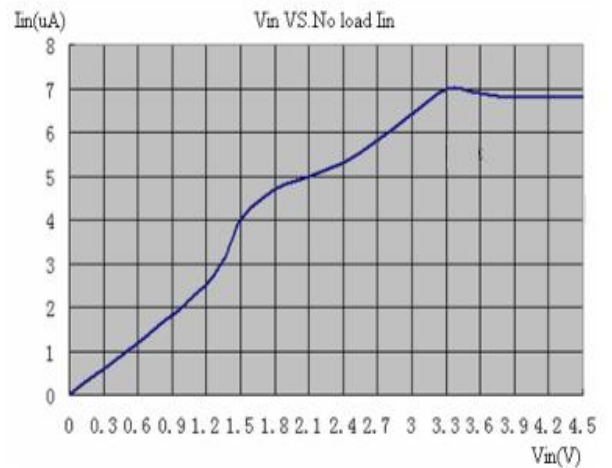
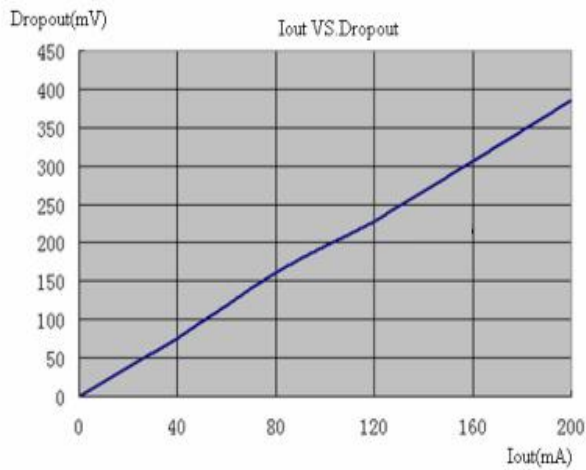
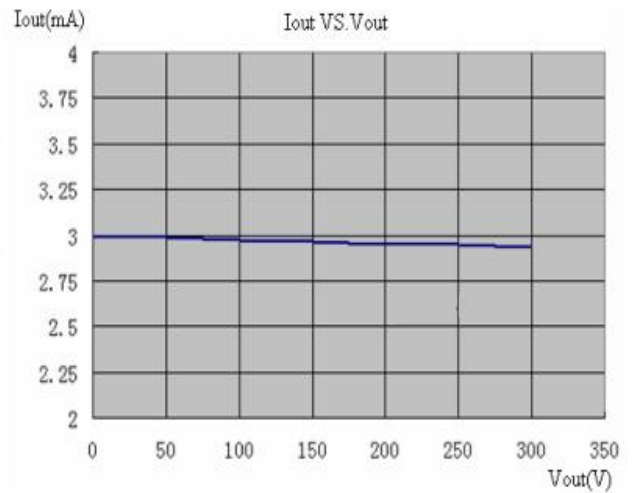
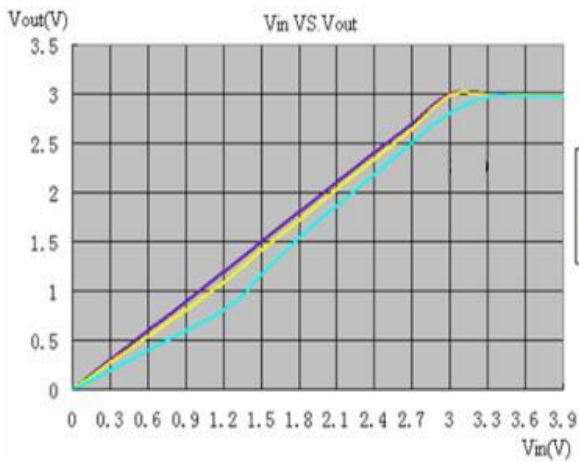

10. SOT23 package outline

**Table6: SOT23 package outline
DIMENSIONS(mm are the original dimensions)**

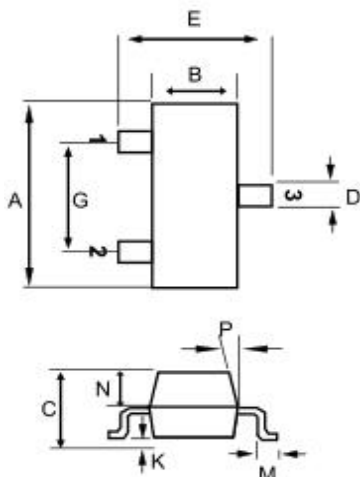

Dim	Min	Max
A	2.70	3.10
B	1.50	1.80
C	1.10	1.30
D	0.30	0.50
E	2.60	3.00
G	1.70	2.10
K	0.00	0.10
M	0.20	
N	0.50	0.70
P	0°	8°