

**VOLTAGE RANGE: 50 - 1000V**  
**CURRENT: 1.0A**

### Features

- Glass passivated device
- Ideal for surface mounted applications
- Low reverse leakage
- Metallurgically bonded construction
- High temperature soldering guaranteed:
- 250°C/10 seconds, 0.375" (9.5mm) lead length, 5 lbs. (2.3kg) tension

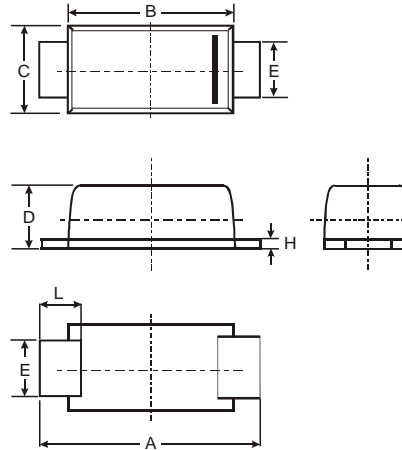
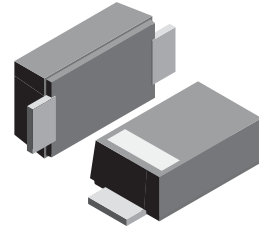

SOD-123FL			
Dim	Min	Max	Typ
A	3.58	3.72	3.65
B	2.72	2.78	2.75
C	1.77	1.83	1.80
D	1.02	1.08	1.05
E	0.097	1.03	1.00
H	0.13	0.17	0.15
L	0.53	0.57	0.55
All Dimensions in mm			

### Mechanical Data

- Case: SOD-123FL plastic body over passivated junction
- Terminals : Plated axial leads,
- solderable per MIL-STD-750, Method 2026
- Polarity : Color band denotes cathode end
- Mounting Position : Any
- Weight: 0.0007 ounce, 0.02 grams



### Maximum Ratings and Electrical Characteristics T<sub>A</sub> = 25°C unless otherwise specified

Single phase, half wave, 60Hz, resistive or inductive load. For capacitive load, derate current by 20%.

Characteristic	Symbol	RS1AL	RS1BL	RS1DL	RS1GL	RS1JL	RS1KL	RS1ML	Unit
Maximum repetitive peak reverse voltage	V <sub>RRM</sub>	50	100	200	400	600	800	1000	V
Maximum RMS voltage	V <sub>RMS</sub>	35	70	140	280	420	560	700	V
Maximum DC blocking voltage	V <sub>DC</sub>	50	100	200	400	600	800	1000	V
Maximum average forward rectified current at T <sub>A</sub> =65°C (NOTE 1)	I <sub>(AV)</sub>	1.0							A
Peak forward surge current 8.3ms single half sine-wave superimposed on rated load (JEDEC Method) T <sub>L</sub> =25°C	I <sub>FSM</sub>	30.0							A
Maximum instantaneous forward voltage at 1.0A	V <sub>F</sub>	1.3							V
Maximum DC reverse current T <sub>A</sub> =25°C at rated DC blocking voltage T <sub>A</sub> =100°C	I <sub>R</sub>	5.0 100.0							μA
Maximum reverse recovery time (NOTE 2)	t <sub>rr</sub>	150			250		500		ns
Typical junction capacitance (NOTE 3)	C <sub>J</sub>	15							pF
Typical thermal resistance (NOTE 4)	R <sub>θJA</sub>	180							K/W
Operating junction and storage temperature range	T <sub>J</sub> , T <sub>STG</sub>	-50 to +150							°C

- Note:**
1. Averaged over any 20ms period.
  2. Measured with I<sub>F</sub>=0.5A, I<sub>R</sub>=1A, I<sub>rr</sub>=0.25A.
  3. Measured at 1MHz and applied reverse voltage of 4.0V D.C.
  4. Thermal resistance junction to ambient, 6.0 mm<sup>2</sup> copper pads to each terminal.

## RATINGS AND CHARACTERISTIC CURVES RS1AL THRU RS1ML

