

Features

- Fast Switching Speed
- Ultra-Small Surface Mount Package
- For General Purpose Switching Applications
- High Conductance

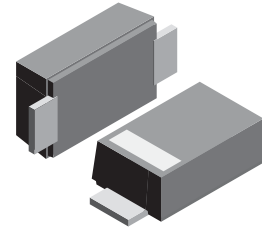

Mechanical Data

- Case: SOD-323, Molded Plastic
- Terminals: Plated Leads Solderable per MIL-STD-202, Method 208
- Polarity: Cathode Band
- Weight: 0.004 grams (approx.)
- Marking: K 4 5

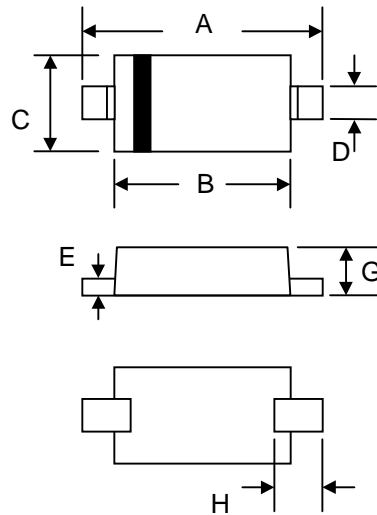

SOD-323		
Dim	Min	Max
A	2.30	2.70
B	1.75	1.95
C	1.15	1.35
D	0.25	0.35
E	0.05	0.15
G	0.70	0.95
H	0.30	—
All Dimensions in mm		

Maximum Ratings @ T_A = 25 °C unless otherwise specified

Characteristic	Symbol	Value	Unit
Peak Repetitive Reverse Voltage Working Peak Reverse Voltage DC Blocking Voltage	V _{RRM} V _{RWM} V _R	45	V
RMS Reverse Voltage	V _{R(RMS)}	40	V
Forward Continuous Current	I _{FM}	100	mA
Forward Surge Current @ t < 8.3ms	I _{FSM}	1.0	A
Power Dissipation	P _d	200	mW
Thermal Resistance Junction to Ambient Air (Note 1)	R _{JA}	500	C/W
Operating and Storage Temperature Range	T _J , T _{STG}	-40 to +125	C

Electrical Characteristics @ T_A = 25 °C unless otherwise specified

Characteristic	Symbol	Min	Typ	Max	Unit	Test Condition
Reverse Breakdown Voltage	V _{(BR)R}	45				I _R = 100 μA
Forward Voltage	V _F		370	450	mV	I _F = 10mA
Reverse Leakage Current	I _R		0.07	1.0	μA	V _R = 10V
Total Capacitance	C _T		6.0		pF	V _R = 10V, f = 1.0MHz

- Note:
1. Device mounted on FR-5 PCB 1.0 x 0.75 x 0.062 inch pad layout as shown on Diodes, Inc. suggests
 2. Short duration pulse test to minimize self-heating effect.

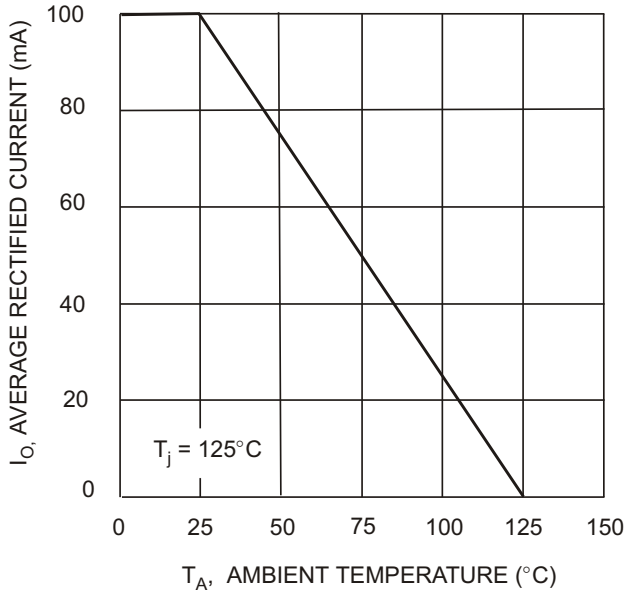

Fig. 1 Forward Current Derating Curve

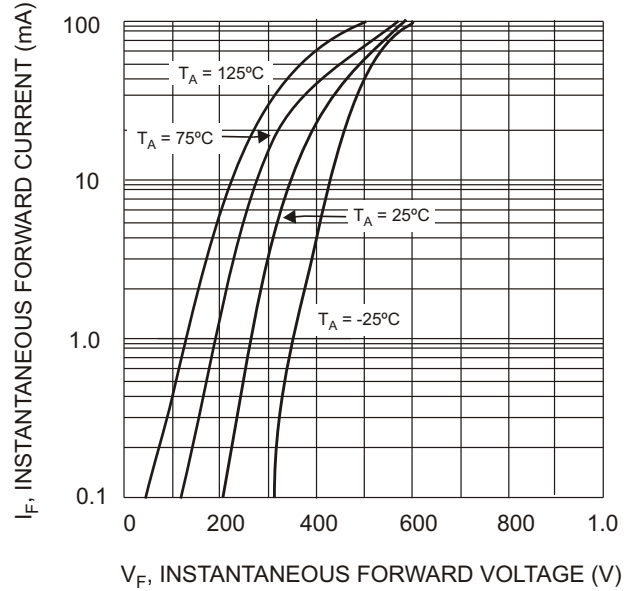

Fig. 2 Typical Forward Characteristics

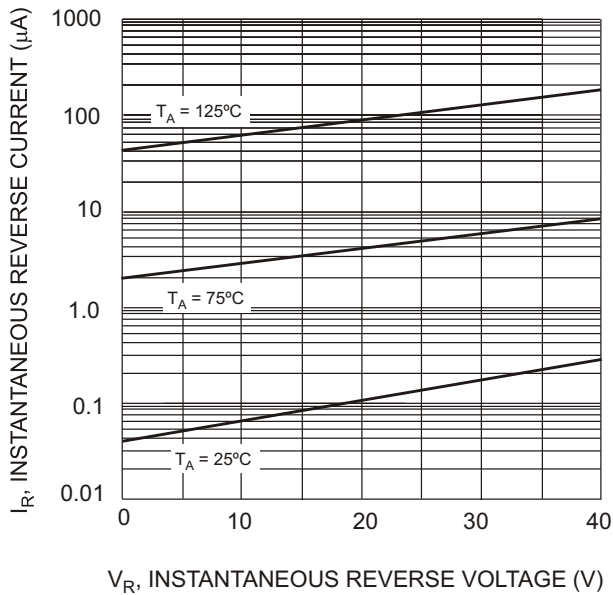

Fig. 3 Typical Reverse Characteristics

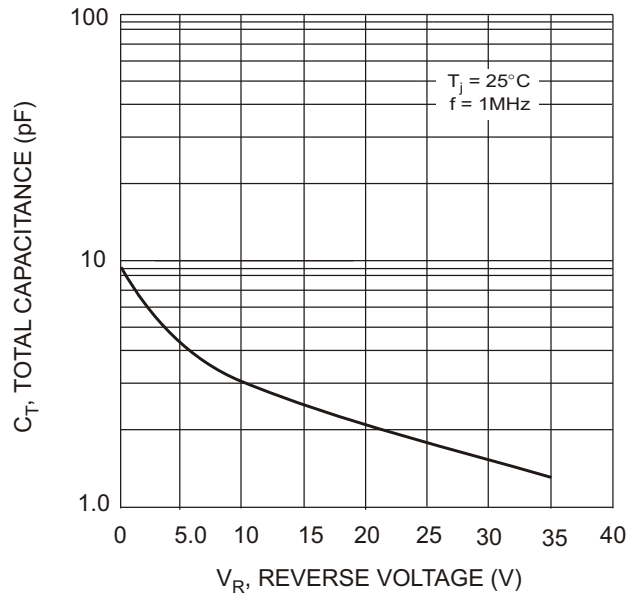

Fig. 4 Total Capacitance vs. Reverse Voltage