



Features

- Silicon Epitaxial Planar Diodes
- Saving space
- Hermetic sealed parts

Mechanical Data

- Case: SOD-323, Molded Plastic
- Terminals: Plated Leads Solderable per MIL-STD-202, Method 208
- Polarity: Cathode Band
- Weight: 0.004 grams (approx.)
- Marking: A3

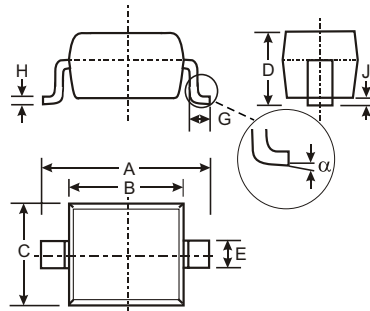

SOD-323		
Dim	Min	Max
A	2.30	2.70
B	1.60	1.80
C	1.20	1.40
D	1.05 Typical	
E	0.25	0.35
G	0.20	0.40
H	0.10	0.15
J	0.05 Typical	
α	0°	8°
All Dimensions in mm		

Maximum Ratings and Electrical Characteristics @ $T_A = 25^\circ\text{C}$ unless otherwise specified

Parameter	Test condition	Part	Symbol	Value	Unit		
Peak reverse voltage		BAV300	V_{RRM}	60	V		
		BAV301	V_{RRM}	120	V		
		BAV302	V_{RRM}	200	V		
		BAV303	V_{RRM}	250	V		
Reverse voltage		BAV300	V_R	50	V		
		BAV301	V_R	100	V		
		BAV302	V_R	150	V		
		BAV303	V_R	200	V		
Forward continuous current			I_F	250	mA		
Peak forward surge current	$t_p = 1 \text{ s}, T_j = 25^\circ\text{C}$		I_{FSM}	1	A		
Forward peak current	$f = 50 \text{ Hz}$		I_{FM}	625	mA		
Parameter	Test condition	Part	Symbol	Min	Typ.	Max	Unit
Forward voltage	$I_F = 100 \text{ mA}$		V_F			1000	mV
Reverse current	$V_R = 50 \text{ V}$	BAV300	I_R			100	nA
	$V_R = 100 \text{ V}$	BAV301	I_R			100	nA
	$V_R = 150 \text{ V}$	BAV302	I_R			100	nA
	$V_R = 200 \text{ V}$	BAV303	I_R			100	nA
	$T_j = 100^\circ\text{C}, V_R = 50 \text{ V}$	BAV300	I_R			15	μA
	$T_j = 100^\circ\text{C}, V_R = 100 \text{ V}$	BAV301	I_R			15	μA
	$T_j = 100^\circ\text{C}, V_R = 150 \text{ V}$	BAV302	I_R			15	μA
	$T_j = 100^\circ\text{C}, V_R = 200 \text{ V}$	BAV303	I_R			15	μA
Breakdown voltage	$I_R = 100 \mu\text{A}, t_p/T = 0.01, p = 0.3 \text{ ms}$	BAV300	$V_{(BR)}$	60			V
	$I_R = 100 \mu\text{A}, t_p/T = 0.01, p = 0.3 \text{ ms}$	BAV301	$V_{(BR)}$	120			V
		BAV302	$V_{(BR)}$	200			V
		BAV303	$V_{(BR)}$	250			V
Diode capacitance	$V_R = 0, f = 1 \text{ MHz}$		C_D		1.5		pF
Differential forward resistance	$I_F = 10 \text{ mA}$		r_f		5		Ω
Reverse recovery time	$I_F = I_R = 30 \text{ mA}, i_R = 3 \text{ mA}, R_L = 100 \Omega$		t_{rr}			50	ns



Typical Characteristics $T_{amb} = 25\text{ }^{\circ}\text{C}$, unless otherwise specified

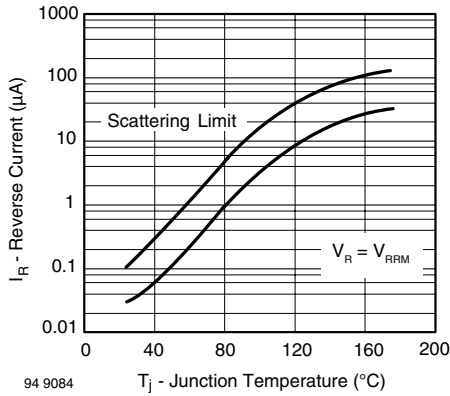

Figure 1. Reverse Current vs. Junction Temperature

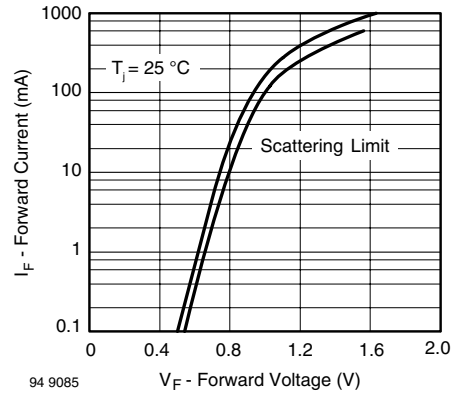

Figure 2. Forward Current vs. Forward Voltage

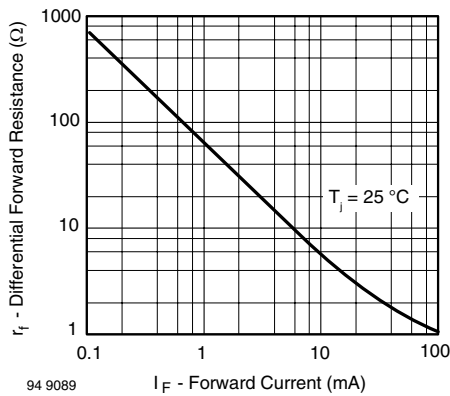

Figure 3. Differential Forward Resistance vs. Forward Current

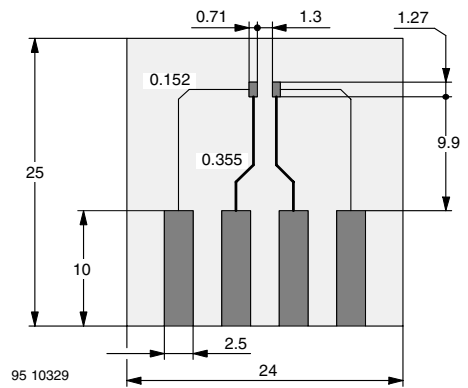

Figure 4. Board for R_{thJA} definition (in mm)