

Features

- High Conductance
- Fast Switching Speed
- Surface Mount Package Ideally Suited for Automatic Insertion
- For General Purpose Switching Application
- Plastic Material – UL Recognition Flammability Classification 94V-0

Mechanical Data

- Case: SOD-323, Molded Plastic
- Terminals: Plated Leads Solderable per MIL-STD-202, Method 208
- Polarity: Cathode Band
- Weight: 0.004 grams (approx.)
- Marking: A3

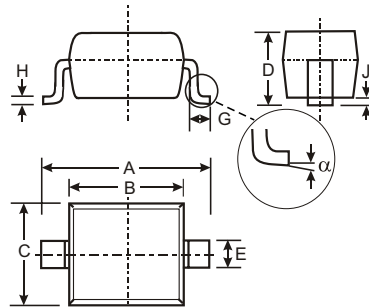
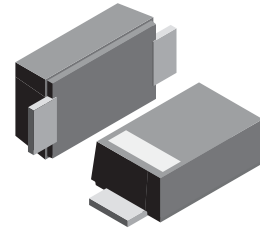

SOD-323		
Dim	Min	Max
A	2.30	2.70
B	1.60	1.80
C	1.20	1.40
D	1.05 Typical	
E	0.25	0.35
G	0.20	0.40
H	0.10	0.15
J	0.05 Typical	
α	0°	8°
All Dimensions in mm		

Maximum Ratings @ $T_A = 25^\circ\text{C}$ unless otherwise specified

Characteristic	Symbol	Value	Unit
Non-Repetitive Peak Reverse Voltage	V_{RM}	100	V
Peak Repetitive Reverse Voltage	V_{RRM}	75	V
Working Peak Reverse Voltage	V_{RWM}		
DC Blocking Voltage	V_R		
RMS Reverse Voltage	$V_{R(RMS)}$	53	V
Forward Continuous Current (Note 1)	I_{FM}	500	mA
Average Rectified Output Current (Note 1)	I_O	250	mA
Non-Repetitive Peak Forward Surge Current	I_{FSM}	4.0	A
		2.0	
Power Dissipation (Note 1)	P_d	200	mW
Typical Thermal Resistance, Junction to Ambient Air (Note 1)	$R_{\theta JA}$	625	K/W
Operating and Storage Temperature Range	T_j, T_{STG}	-65 to +150	$^\circ\text{C}$

Electrical Characteristics @ $T_A = 25^\circ\text{C}$ unless otherwise specified

Characteristic	Symbol	Value	Unit
Forward Voltage Drop	V_{FM}	0.72	V
		1.0	
Peak Reverse Leakage Current	I_{RM}	2.5	μA
Junction Capacitance ($V_R = 0\text{V DC}, f = 1.0\text{MHz}$)	C_j	4.0	pF
Reverse Recovery Time (Note 2)	t	4.0	nS

Note: 1. Valid provided that terminals are kept at ambient temperature.
 2. Measured with $I_F = I_R = 10\text{mA}$, $I_{RR} = 0.1 \times I_R$, $R_L = 100\Omega$.

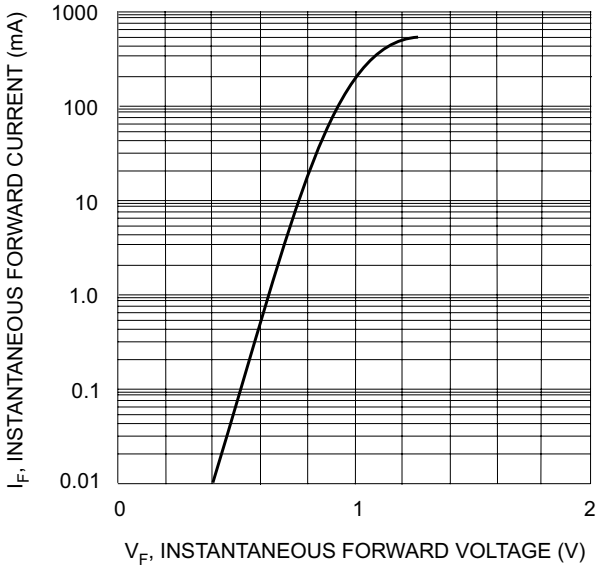

Fig. 1 Forward Characteristics

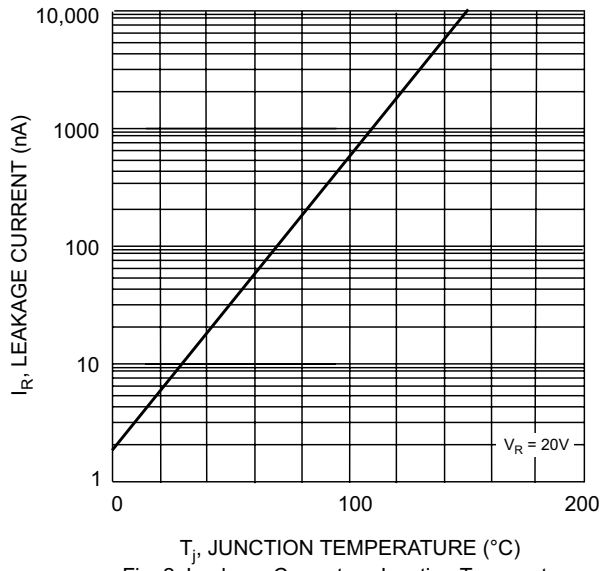

Fig. 2 Leakage Current vs Junction Temperature