

Features

- Low V_F
- High current capability
- Miniature surface mount package

Mechanical Data

- Case: SOD-323, Molded Plastic
- Case material - UL Flammability Rating Classification 94V-0
- Marking: S40
- Weight: 0.004 grams (approx.)

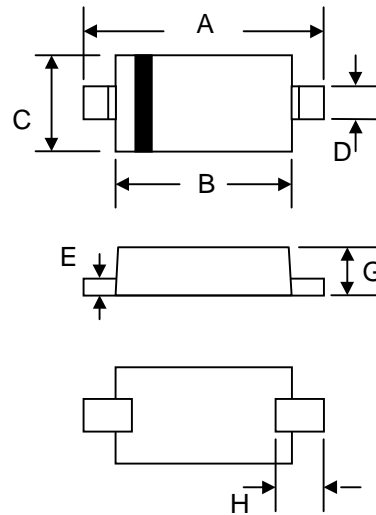

SOD-323		
Dim	Min	Max
A	2.30	2.70
B	1.75	1.95
C	1.15	1.35
D	0.25	0.35
E	0.05	0.15
G	0.70	0.95
H	0.30	—
All Dimensions in mm		

Maximum Ratings @ $T_A = 25^\circ\text{C}$ unless otherwise specified

PARAMETER	SYMBOL	VALUE	UNIT	
Continuous Reverse Voltage	V_R	40	V	
Forward Current (Continuous)	I_F	400	mA	
Forward Voltage @ $I_F = 400\text{mA}$	V_F	500	mV	
Average Peak Forward Current; D.C. = 50%	I_{FAV}	1000	mA	
Non Repetitive Forward Current	I_{FSM}	$t \leq 100\mu\text{s}$	6.75	A
		$t \leq 10\text{ms}$	3	A
Power Dissipation at $T_{amb} = 25^\circ\text{C}$	P_{tot}	250	mW	
Storage Temperature Range	T_{stg}	-55 to +150	$^\circ\text{C}$	

PARAMETER	SYMBOL	MIN.	TYP.	MAX.	UNIT	CONDITIONS
Reverse Breakdown Voltage	$V_{(BR)R}$	40	60		V	$I_R = 200\mu\text{A}$
Forward Voltage	V_F		270	300	mV	$I_F = 50\text{mA}$
			300	350	mV	$I_F = 100\text{mA}$
			370	460	mV	$I_F = 250\text{mA}$
			425	500	mV	$I_F = 400\text{mA}$
			550	670	mV	$I_F = 750\text{mA}$
			640	780	mV	$I_F = 1000\text{mA}$
			810	1050	mV	$I_F = 1500\text{mA}$
	440		mV	$I_F = 500\text{mA}, T_{amb} = 100^\circ\text{C}$		
Reverse Current	I_R		15	40	μA	$V_R = 30\text{V}$
Diode Capacitance	C_D		20		pF	$f = 1\text{MHz}, V_R = 25\text{V}$

